

SIP Trunking

Streamline your network for maximum efficiency.

Consolidate the transmission of voice, data and other applications in several locations nationwide without the need for separate circuits for each service. Leverage IP data connectivity to run local, long distance, and private voice traffic.

The perfect voice and data solution



Improve business efficiency

- Reduce or eliminate the need for multiple circuits freeing up IT professionals' time
- Maximize unified communication features, allowing remote teams to easily access and collaborate with video conferencing, virtual white boarding and instant messaging



Easily manage costs

- Scalable price bundles allow you to only pay for what you need
- Reduce capital costs by using your existing IP communications equipment and phones†
- Enjoy competitive long-distance and international calling rates outside your IP network



Peace of mind with a reliable and secure network

- With the Shaw Business 'self-healing' MPLS network you can be assured that your voice service will be resilient
- Reduced hardware in each location allows for less potential points of failure
- Interoperability testing to ensure our SIP Trunking and your SIP enabled PBX work seamlessly

Shaw Business customers always enjoy the following benefits:

- 24/7/365 proactive technical monitoring by a trained Network Operations Centre (NOC), specialized to work with our business clientele
- Commitment to industry leading Mean Time To Repair service levels including local field technicians, regional distribution centres and comprehensive electronics sparing

For more information contact your local Shaw Business Authorized Partner

SIP Trunking

As low as

\$12⁴⁵* /session
on a 3-year term.

Over
40% off



Shaw) Business
Authorized Partner

*Offer is based on a three-year commitment and is subject to change without notice. Available to new customers who have not subscribed to Shaw Business SIP product within the last 60 days. Prices shown do not include tax. Regular rates subject to change. **Where available. †In accordance with make and models that have been pre-tested with Shaw Business' network.

Additional features available

Inbound Calling Direct Inward Dials (Ported and New)	Account Codes
800 (8xx) Inbound	Inbound Calling Name & Number Display**
900 Dialing Restriction	Calling Number Delivery
DID Level 911	Calling Name Delivery
411 & Basic Operator Services	Ability to dial 310 services
611 Repair	LD & International dialing
311 (where applicable)	G.711 Codec Support (uncompressed voice)
711 Message Relay Service	Hunting Features

Understanding SIP Implementation

Single location business

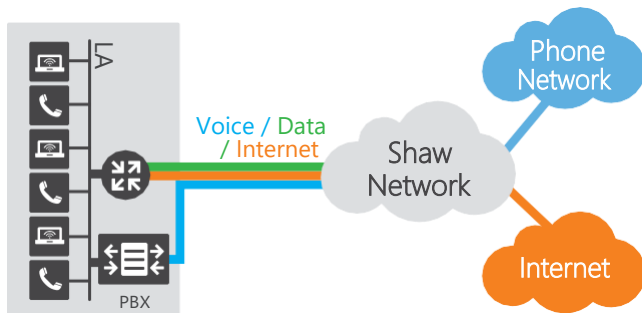

Multi location business

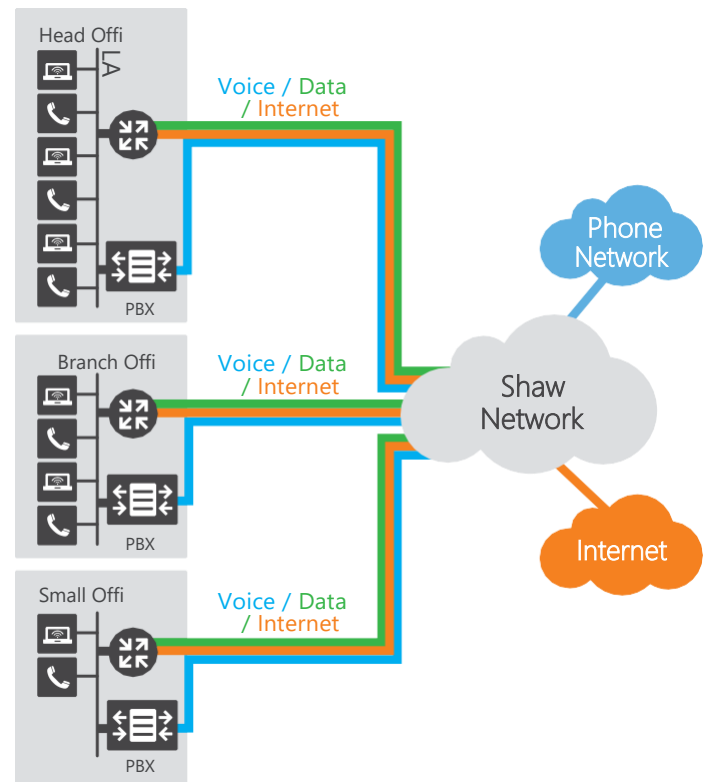

For more information contact your local Shaw Business
Authorized Partner

Integrated Telecom Solution Sourcing
Phone: 1-855-558-4877, ext 4636
Email: info@itssi.ca

Shaw Business
Authorized Partner